

The JPL Mars Cube One (MarCO) is the first interplanetary CubeSat and is propelled by VACCO's smart, self-contained Micro Propulsion System (MiPS)

The MarCO MiPS is an all-welded aluminum system-in-a-tank design with propellant storage, feed system, thrusters, and a controller based on VACCO's patented Chemically Etched Micro Systems (ChEMS)™ technology.

This unit is designed to control a 6U CubeSat and can be easily application-engineer for other CubeSat configurations.



SPACE

Features

- Smart, Self-contained MiPS
- 755 N-Sec total impulse
- Inherently safe non-toxic R236fa propellant.
- 3490 gram wet mass
- 4 axial and 4 RCS 25mN thrusters
- Two interrupts against leakage
- Microcontroller driven
 - RS-422 interface
 - Controls burn type and duration
 - Closed-loop, variable thrust control
 - 3 settable thermal control zones
 - 3 power supplies with 9 valve drivers

Optional Features

- Propellant purity sensor
- Radiation sensor
- Time stamp
- MEMS gyroscope
- Accelerometer
- Magnetometer

Operating Parameters

- 755 N-Sec total impulse
- 3490 gram wet mass
- Operating temperature: -30C to +55C
- Minimum impulse Bit: 0.5mN-Sec
- Operating Voltage: +9 to +12.6 VDC
- Thruster valve response time: <20 msec

Performance characteristics are based on customer requirements. As such, they are not representative of component capabilities or limitations.

Envelope Drawing

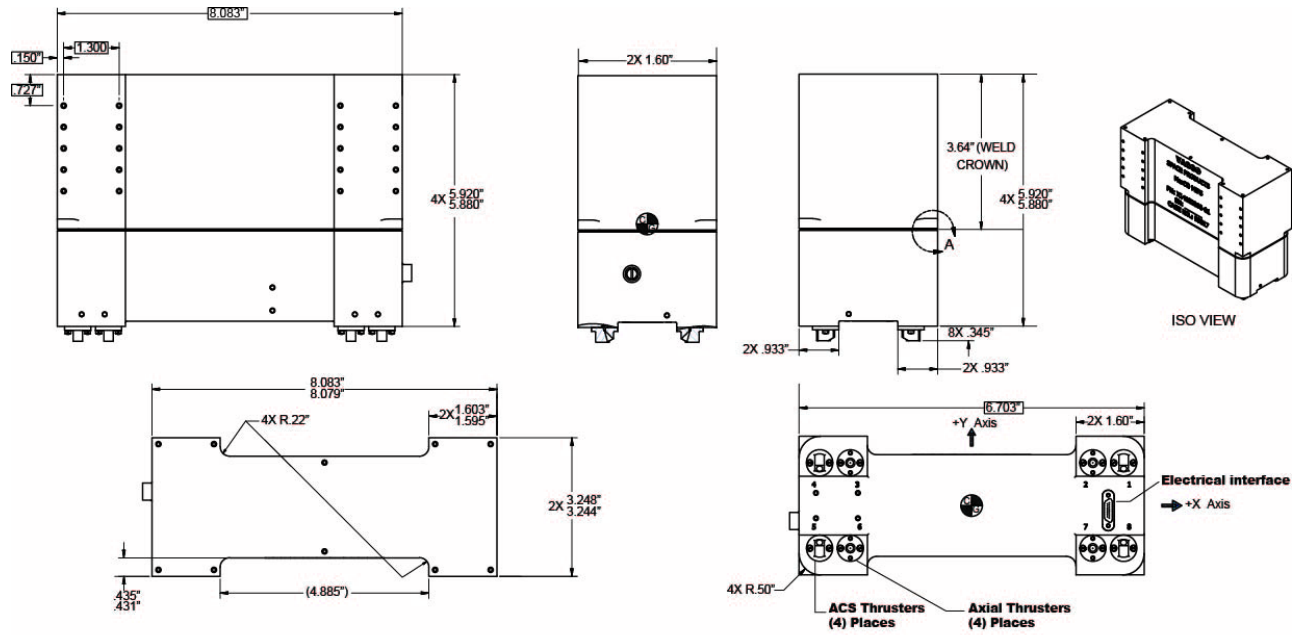

Preliminary MarCO MiPS Schematic

